



HD-01-EX- Flame Detector Manual

Publication 372001-23 Rev. B

● BURNERS ● IGNITERS ● DAMPERS ● CONTROLS



www.forneycorp.com

WOOCHANG ELECTRIC Co., Ltd.
www.woochang.co.kr

INTRODUCTION



TECHNICAL RELEASE LOG

REV	MODIFICATION	DATE
A	Initial Release	03/12/2021
B	Vibration Specification Update	11/10/2023



NOTICE: Read this manual in its entirety before commencing work of any kind. Only experienced personnel familiar with this type of equipment, should install, setup, and service this equipment.



WARNING: Never use this equipment in any manner for which it was not designed. Improper use can severely impact user safety. The Forney Corporation cannot be held liable for any damages resulting from such use! Failure to heed this warning COULD result in death or serious injury.



NOTICE: The equipment serial number should be referenced any time that contact is made with Forney. The serial number can be found on the Forney Data Label/Plate (mounted on the equipment).



NOTICE: If any of the procedures or instructions provided in this manual are unclear, contact Forney for resolution. Forney Corporation offers complete, on-site service solutions to ensure proper installation, programming, commissioning, and troubleshooting.

TABLE OF CONTENTS



TABLE OF CONTENTS

0.1 Introduction	iv
0.2 Proprietary Notice	iv
0.3 Safety Awareness	iv
0.4 Personal Protective Equipment (PPE)	iv
0.5 Typical Safety Alert Symbols and Action Icons	v
0.6 Additional Documentation	v
Section 1 Equipment Description	1
1.1 Summary	1
1.2 Dimensions	2
1.3 Technical Data	3-7
1.4 Accessories and Cables	8
1.5 Codes, Standards, and Agency Approvals	9
Section 2 Equipment Installation	10
2.1 Location	10
2.2 Required Site-Service Connections	11
2.3 Installation Procedure	11-14
2.4 Wiring	15
2.4.1 Grounding and Shielding	16
2.4.2 Communication Wiring	17
Section 3 Setup and Configuration	18
3.1 Tuning	18-20
3.2 Mobile App	21
3.3 Desktop App	21
3.4 Bluetooth Enable/Disable	21
Section 4 Service and Troubleshooting	21
4.1 Service	22
Coordination	22
Handling	22
Storage	22
4.2 Troubleshooting	23
Section 5 Aftermarket	24
5.1 RMA / Warranty	24
5.2 Parts and Accessories	24
5.3 Enclosure	25
Section 6 Appendix	26
6.1 Common Acronyms	26
6.2 Common Regulatory Agencies	27

0.1 INTRODUCTION

This manual serves as a guideline to service technicians for the basic installation, setup, and troubleshooting of the HD Flame Detector, manufactured by Forney Corporation: 16479 Dallas Parkway, Suite 600, Addison, TX 75001.

The flameproof enclosure used for Exd protection type is manufactured by Woochang Electric: 14-11, Mugap-gil 140beon-gil, Chowol-eup, Gwangju-si, Gyeonggi-do, Korea.

All personnel should become thoroughly familiar with the contents of this manual prior to installing, setting-up and servicing this equipment. Because it is virtually impossible to cover every situation that might occur during operation and maintenance of the equipment described in this publication, personnel are expected to use good engineering judgment when confronted with situations that are not specifically mentioned herein.

0.2 PROPRIETARY NOTICE

The contents of this publication are proprietary data of Forney Corporation and Woochang Electric. Reproduction or use of any part of the publication for purposes other than the support of the equipment for which it is published is permissible only if expressly authorized in writing by us.

0.3 SAFETY AWARENESS





Safety is YOUR responsibility and must always be primary concern. The guidelines covered in this manual will greatly improve your ability to safely install and maintain this equipment. It is the equipment owner's responsibility to ensure that the concerned personnel fully understand and abide by all site-specific Health, Safety, and Quality protocols. Safety summaries and procedures can never replace good common sense!

0.4 PERSONAL PROTECTIVE EQUIPMENT (PPE)

All involved personnel should follow their site-specific Health, Safety, and Quality guidelines.

0.5 TYPICAL SAFETY ALERT SYMBOLS AND ACTION ICONS

All labels in this manual should be carefully observed, read, and understood. Standard labels are as follows:

	DANGER	Indicates a hazardous situation which, if not avoided, will result in death or serious injury.
	WARNING	Indicates a hazardous situation which, if not avoided, could result in death or serious injury.
	CAUTION	Indicates a hazardous situation which, if not avoided, could result in minor or moderate injury.
	NOTICE	Provided to notify personnel of potential damage to equipment. This label can also contain important operational information and/or tips that may be useful. These labels are not related to personal injury.

0.6 ADDITIONAL DOCUMENTATION

HD Connect Manual (Publication # 372001-22) if using Desktop Application/Software

Forney App Manual (Publication # 372001-21) if using Mobile App

SECTION 1

EQUIPMENT DESCRIPTION

1.1 SUMMARY

The HD Flame Detector (Model HD-01-EX) is a state-of-the-art flame detector by Forney Corporation which comprises multi-sensor technology, an on-board microprocessor, Bluetooth® connectivity, and optional fiber-optics attachment. The HD Flame Detector is sensitive to ultraviolet light from 210 to 390 nm wavelengths, and infrared light from 900 to 1700 nm wavelengths. The HD Flame Detector is an integrated equipment housing all components and subsystems into a single housing eliminating the need for a remote amplifier yet has a small form factor.

The HD Flame Detector contains two flame relays: Flame Relay 1 (FR1) and Flame Relay 2 (FR2). FR1 is pre-programmed to respond to IR radiations while FR2 is pre-programmed to respond to UV radiations from target flame.

The HD Flame Detector has two 6-pin connectors to receive 24 VDC power and for interconnections with the Burner Management System (BMS). The HD Flame Detector includes a Bluetooth® chip to connect with any Bluetooth® equipped smart phone, tablet, or laptop using Forney App. The Forney App is available in the Apple App Store and Google Play Store. The Bluetooth® can be disabled using Desktop App if required.

Furthermore, the HD Detectors can also be connected to a laptop using RS-485 communication link by utilizing Modbus RTU protocol for remote monitoring and configuration. HD Connect (Forney's HD Flame Detector Software for Desktop/laptop) is available as Modbus Master for polling and visualization of live data streaming from connected detectors.

Model HD-01-EX Detector is suitable for IEC, KS and ATEX II 2G hazardous locations. It consists of a metal housing, cover and two light-transmitting windows. These are secured in an aluminum alloy housing with the aid of epoxy. Housing is rated for to IP66 degree of protection. The cable length can be customized to suit application requirements.

The installation shall comply with the IEC/EN/KS C 60079-14 and local standards related to explosion proof equipment.

The HD Detector is suitable for use in a variety of industries such as oil, gas, etc. and across several applications such as gas-fired industrial burners, utility burners, waste fuel burners, duct burners and igniters. A fiber-optic assembly can be used if direct sighting of a target flame is not possible.

Figure 1 – HD Flame Detector



1.2 DIMENSIONS

Figure 2 - HD Flame Detector Dimensions

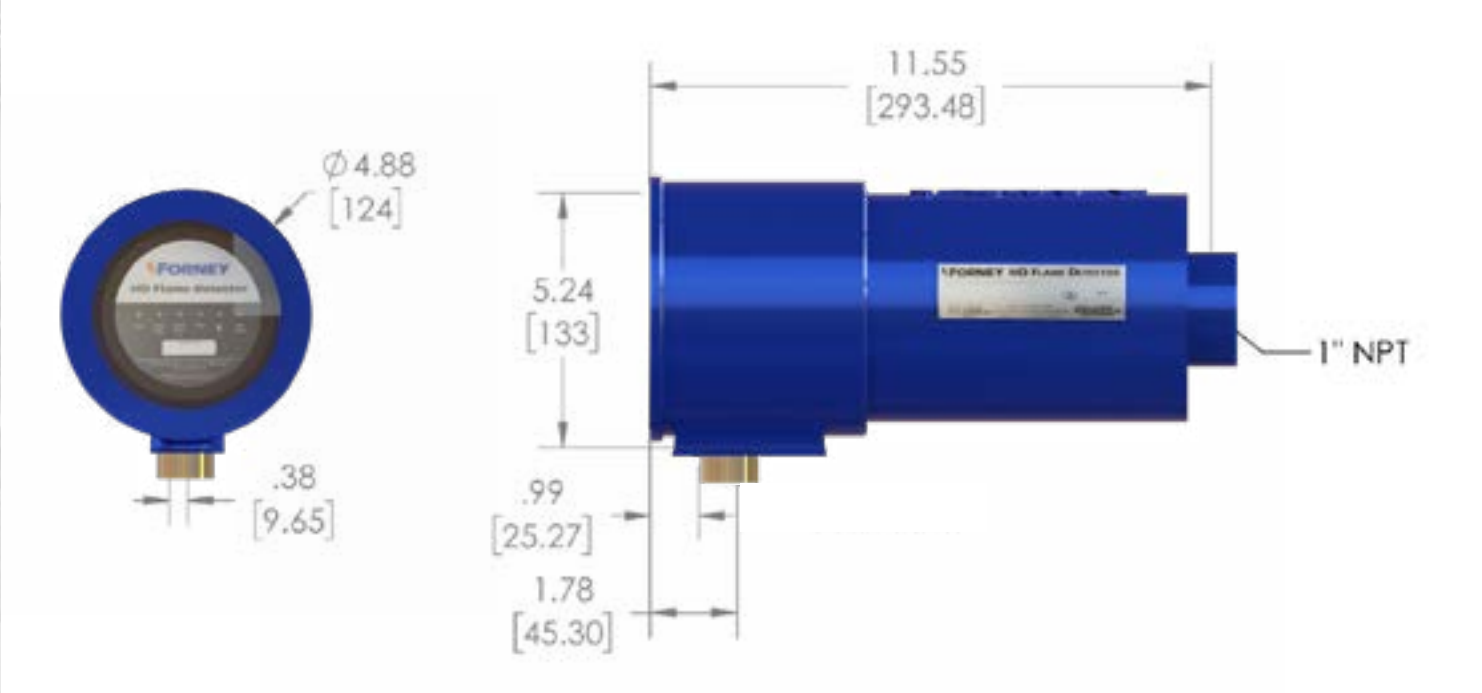

1.3 TECHNICAL DATA

Electrical

Power Supply:	24 VDC (+10 /-15%)
Steady State Current:	120 mA
Inrush Current:	350 mA
Power Consumption:	2.9 Watt
External In-line Fuse:(Required)	500 mA Fuse (Customer Furnished)
Heat Dissipation:	2.8 Watt
Flame Relay:	2 Independent (fail safe)
Contacts: (External 500 mA Fuse Required in series)	SPST, 24 VDC, 500 mA
Conformal Coating:	Yes
Relay Operating Cycle:	> Min 20 X 10 ⁶ Operations
Flame Failure Response Time (FFRT):	1, 2, 3, 3.8 second (user adjustable)
Fault Relay:	Internally Wired in series with flame relay contact
Analog Output:	Two Sourced 4-20 mA, Load resistance < 500 Ohm
Profile Selection Digital Inputs:	2 Self-Powered Inputs
Communication (Wired):	RS-485 (Modbus RTU Protocol)
Communication (Wireless):	Bluetooth® Low Energy

Mechanical

Housing Material:	Aluminum Alloy, glass and epoxy
Weight:	7.72 lbs. (3.5 Kgs.)
Degree of Protection:	IP66
Connection Interface:	1" NPT, 3/4" NPT, M25, M32 (female)
Lens Temperature Rating:	1000°F (538°C)
Purge Air Pressure:	5 SCFM (minimum)

Environmental

Ambient Operating Temperature:	-20°F to 149°F (-20°C to 65°C1)
Ambient Storage and Transportation Temperature:	68°F to 122°F (20°C to 50°C)
Internal Operating Temperature:	Up to 185°F (85°C)
Relative Humidity:	RH 95% 104°F (40°C)
Vibration Sinusoidal Operating:	Frequency: 0-5 Hz / Acceleration: 2G
Flammability Rating:	Non Combustible

Optical Sensitivity

IR:	900 to 1700 nm
UV:	210 to 390 nm

Connection

Connector:	Use only certified Ex entry device, more than IIC and IP66
Cable:	6/C + 3PR #18 AWG 7/Strands BC PVC/Nylon Tinned Copper Braid Shield Black PVC Jacket CSA CMG (UL) PLTC-ER 300V 105C
Diameter:	0.463" Nominal
Weight:	0.17 lb./ft.
Fire Resistant:	FT4, UV Resistance

¹For Hazzard area, Temperature Rating is T6 which pertains to maximum Ambient temperature of 65°C

Figure 3 - HD Flame Detector Faceplate



The HD Flame Detector faceplate has six (6) status LEDs to display real-time operating conditions:

- Power (Green) - Steady when the unit is on. Flashing when the detector settings are updated in tuning mode.
- Flame Relay 1 (Yellow) - Steady when the Flame Relay 1 (IR) is in the “ON” state.
- Flame Relay 2 (Yellow) - Steady when the Flame Relay 2 (UV) is in the “ON” state.
- Fault (Red) - Steady when the Detector faults; off otherwise. The fault can be reset by power-cycling the unit and after clearing faults using Mobile/Desktop application.
- Bluetooth® (Blue) - Flashing when available for Bluetooth® connection. Steady when connected to the Forney App via a mobile device. OFF when Bluetooth® is disabled.
- High Temperature (Yellow) - Flashing when Detector internal temperature exceeds 80°C (175°F). Steady if the Detector internal temperature exceeds 85°C (185°F). The Fault LED (Red) also becomes steady when temperature exceeds 85°C (185°F). The LED turns OFF after temperature falls below 80°C.
- The Forney HD Detector provides two (2) independent analog current (4-20 milliampere) outputs sourced from the internal power supply. Each analog output represents flame intensity of each respective Flame Relay. The minimum and maximum scale values are user adjustable based on customer requirements. Each analog output channel is protected against inadvertent connection of the 24 VDC power or grounding.



NOTICE: Analog outputs are generally representative of the flame intensity and are intended for display on the operator console only. Analog output signals are not representative of quality of combustion and must not be used as ‘loss of flame’ input to safety control loops of the Burner Management System.

The “normally open” contact of each Flame Relay is wired in series with a “normally open” contact of an independent Fault Relay. The fault relay remains energized when no fault is present. The fault can be reset by power-cycling the unit. In event of the HD Detector going into a Fault state, analog output for faulty channel will drop to about 3.6 mA. Forney recommends analog input channel diagnostics on DCS input module should be enabled to detect / record detector fault condition for display and control function.

In addition to internal watchdog monitor of the microprocessor, the Forney HD Detector includes an independent external watchdog supervisor. In the event of internal watchdog failure, the external watchdog supervisor forces both Flame Relays to “Off” state, irrespective of the microprocessor output status and Fault LED turns steady red.

Two (2) profile select inputs are available for selecting up to four (4) different profiles. Each profile select input is triggered by 24 VDC external input power. Each input must be connected to DC common via a normally open potential free contact controlled by the burner management/control system. On closure of normally open contact, Profile select input status switches to logic high (1).

Profile Select Input 1 Status	Profile Select Input 2 Status	Active Profile
Low	Low	0
High	Low	1
Low	High	2
High	High	3



NOTICE: Any change of status of profile select input results into active profile change for both Flame Relay 1 and 2. The use of different profiles for diverse operating conditions such as different boiler loads or diverse fuels is a powerful tool to improve flame detection and discrimination performance.

The Forney HD Detector is shipped with a unique name as displayed on Forney App. This name is structured as FCXXXX, where XXXX matches the last four digits of the Serial Number on the device. The user can rename the device to match instrument tag assigned to the location of installation, if required.

The Forney HD Detector is shipped with a unique Modbus slave ID. The last three (3) digits of the serial number are the slave ID of the detector. The customer can reassign Modbus slave ID using Forney App.

Analog signals from each sensor are generated via a two-stage amplifier (Preamplifier and Amplifier) prior to processing by the microprocessor. Gain for each stage of the amplifier is user adjustable between 0-255. Preamplifier Gain can be set for automatic adjustment mode. In Automatic mode, Pre-Amp gain is optimized to keep Preamp Signal level close to highest (600). Under dark furnace conditions, automatic Gain control keeps the Pre-Amp Gain pegged at a lower level to avoid saturating the signal. Gain for the final stage of the two-stage amplifier is manually adjusted during tuning mode.

Results of Fast Fourier Transformations (FFT) of the signals from each sensor are displayed on the spectrum screen. The user can identify up to two frequency windows where the signal amplitude differences is largest between when target flame is on and off. The Flame Relay is turned on when signal amplitude in any of the two frequency windows is higher than the pickup set point. Whereas the Flame Relay is turned Off when signal amplitude is less than the drop out set point in both frequency windows. User can select Weight Factors to increase signal amplitude, where signal levels from target burner flame are low due to poor sighting issues.

1.4 ACCESSORIES AND CABLES

The HD Detector is to be installed with the provided cable. Cable & matching gland must be ordered separately in increments of 10 feet.

The HD Detector can be mounted on a 1" NPT pipe thread. Forney strongly recommends the use of a swivel-mount to enable improved sighting of the target flame; and a quartz window to protect lens & debris accumulation. The following additional accessories can be ordered if special handling or different mounting options are required

Part Number	Description
HD-01-EX-N01	HD Flame Detector suitable for 1" cable Gland, suitable for Class1 Div 1 / Zone 1 area.
HD-01-EX-N34	HD Flame Detector suitable for 3/4" cable Gland, suitable for Class1 Div 1 / Zone 1 area.
HD-01-EX-M32	HD Flame Detector suitable for M32 cable Gland, suitable for Class1 Div 1 / Zone 1 area.
HD-01-EX-M25	HD Flame Detector suitable for M25 cable Gland, suitable for Class1 Div 1 / Zone 1 area.
HD-01-EX-PF01	HD Flame Detector suitable for PF 1" X 2.309P cable Gland, suitable for Class1 Div 1 / Zone 1 area.
HD-01-EX-PF034	HD Flame Detector suitable for PF 3/4" X 1.814P cable Gland, suitable for Class1 Div 1 / Zone 1 area.

Swivel Mount	91016-63
Quartz Window (Sealing Union)	41075301 (SS304) or 41075302 (SS316) ²
Non-metallic, 1" NPT, Mounting Flange	9114793
Non-metallic, 1" BSP, Mounting Flange	9114782
Bulk Cable	92615-18
UV Fiber Optic Spacer	409613-01
IR Fiber Optic Adaptor	358824-01
	358824-02
	358824-03

²Quartz window are not an optional item instead a required accessory for pressurized furnaces.

1.5 CODES, STANDARDS AND AGENCY APPROVALS

The HD Flame Detector is designed to meet several industry codes and standards. Subsequently, the CE, UL, IEC, FM, and ATEX approvals have been obtained.

Table 1 - Codes and Standards

Code/Standard	Description
IECEX	IECEX KGS 21.0000X Ex db IIC T6 Gb IEC 60079-0:2017 IEC 60079-1:2014
ATEX	KRH 21 ATEX 0000X ⊕ II 2G Ex db IIC T6 Gb EN 60079-0:2018 EN 60079-1:2014
KCs	21-GA2BO-0000X Announcement 0000-00 of Ministry of Employment and Labor
Enclosure Type	IP66, IEC 60529:2013
EN298	Automatic Burner Control System for burners and appliances burning gaseous or liquid fuels
IEC 654-3, IEC 60068-2-6	Vibration Resistant: Severity Class VH4.
IEC 60068-2-27	Shock Resistant
RoHS	Directive 2002/95/EC
IEC 60068-2-27	Shock Resistant
RoHS	Directive 2002/95/EC

SECTION 2

EQUIPMENT INSTALLATION

The purpose of this section is to ensure that the HD Flame Detector is installed using recommended Forney practices.



NOTICE: This manual only recommends best practices for successful installation. Improper installation may result in faulty flame detection.

Flame Detector consists of Aluminium alloy, glasses, Silicone O-ring and epoxies. User has to take an account of chemical reaction caused by environment substances. If you need more information of material, please contact us.

No modifications to the flamepaths are permitted without consultation with the controlled documentation or certified body.

2.1 LOCATION

- Ensure that the installation port has a clear line-of-sight to the flame.
- Ensure that proper wiring/cabling (instrumentation) trays are utilized to prevent damage to wires/cables.



WARNING: If running wires/cables through hazardous areas is unavoidable, ensure that cables are installed in accordance with recommendations of IEC, ATEX directive, KS and other applicable codes.

- Ensure that the HD Flame Detector wiring/cabling is located at a safe distance from high voltage lines.
- HD Flame Detector should be installed at locations with lowest heat dissipation from the burner/boiler to minimize heat transfer to the unit from the surroundings.



NOTICE: For locations where ambient temperatures above 65°C (149°F) are expected, position the HD Detector further from the heat source, by extending the “pipe mount” to minimize the heat. If in doubt, consult Forney to determine suitable methods to minimize heat to the unit.

HD Cooling Jacket can be ordered through Forney After Sales if High Ambient Temperature is a concern.



WARNING: DO NOT OPEN WHEN AN EXPLOSIVE ATMOSPHERE IS PRESENT
WARNING: POTENTIAL ELECTROSTATIC CHARGING HAZARD, CLEAN WITH DAMP CLOTH

Use of IP66 rated & certified Ex entry device according to IEC, EN, KS etc.
Entry device must be installed in accordance with manufacturer’s recommendation.

2.2 REQUIRED SITE-SERVICE CONNECTIONS

The HD Flame Detector requires a 24VDC power source. Forney strongly recommends use of 24 VDC input power source with low output ripple voltage to keep power supply induced noise to minimum. An in-line 500 mA fuse must be added to the input power line to limit potential fault current level. Furthermore, additional fuse should be added in series with the fault relay contacts to limit potential fault current.



NOTICE: Ensure that the supply voltage matches the information provided in section 1.3 Technical Data prior to connecting power to the unit.

Forney also recommends the following, as applicable:

- Customer supplied conduit (flex and rigid) properly rated for the use.
- Pre-Plan conduit runs as necessary.
- Plan runs with service and expansion loops, as needed.



NOTICE: During installation, it is advisable to use electrical “service loops” to account for equipment movement when in operation and aid in future service of the HD Flame Detector(s). Failure to heed this notice could severely impact future maintenance/service efforts.

- All the conduits should be inspected for defects and abnormalities. In addition, they should be cleaned for debris prior to installation. Compressed air may be used to remove debris.

2.3 INSTALLATION PROCEDURE

1. The HD Flame Detector should be installed such that the line of sight intersects the center of flame’s primary combustion zone at about 5° angle as shown in **Figure 4**. If burner and igniter share the same flame detector, then the line of sight should also intersect with the igniter flame in the similar manner.

Figure 4 - Line-of-Sight Diagram

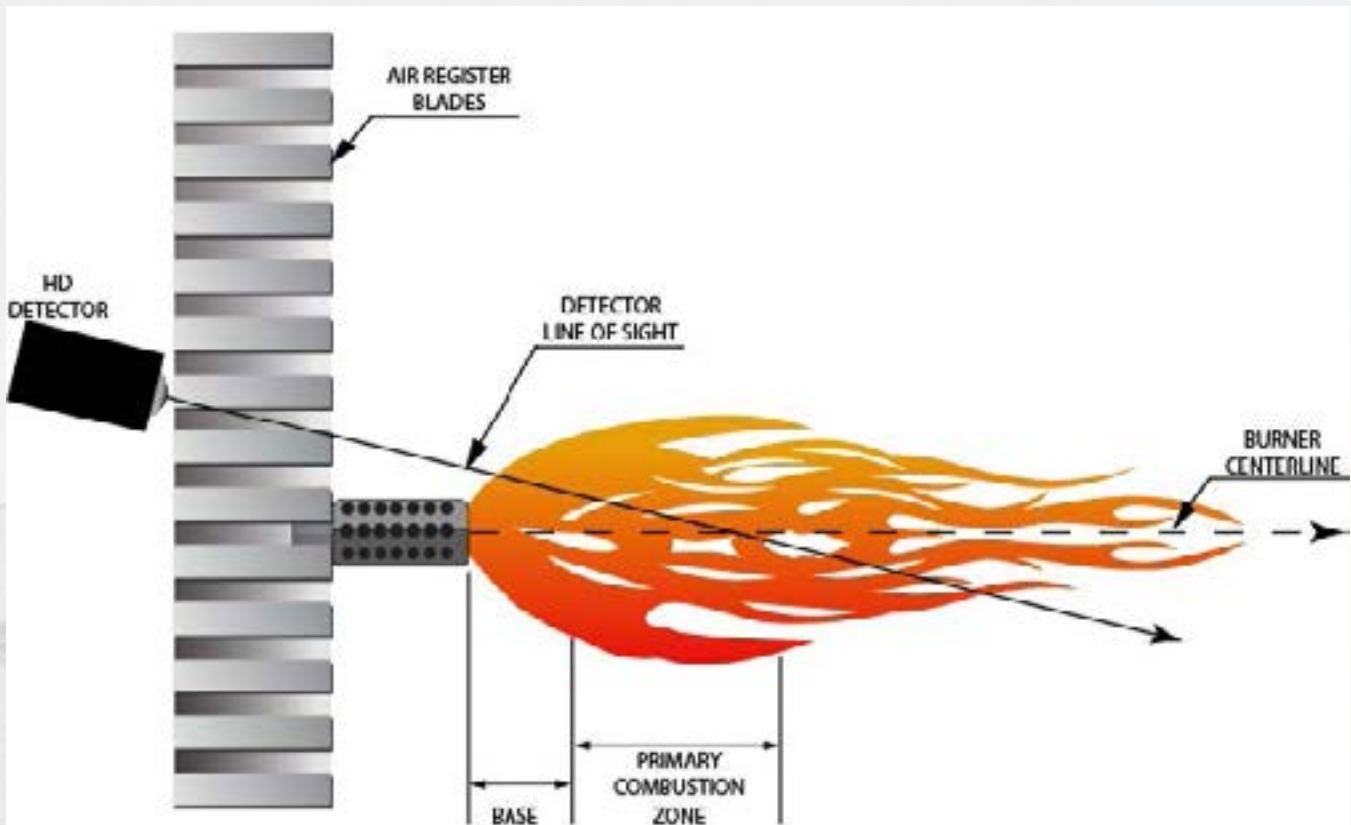

2. For installations where separate detectors are used to monitor burner and igniter flames, the main burner flame detector should be installed such that it does not detect the igniter flame.
3. It is essential that the detector have an unobstructed view of the flame. Furthermore, the detector should aim at the primary combustion zone as shown in **Figure 4**. Physical obstructions such as air register blades, interfering vanes, or other hardware should be cut or notched so they do not interfere with detector's operation. Ideally, the flame should cover the entire cross-section of the line-of-sight tube as shown in **Figure 5**.

Figure 5 - HD Detector Sight Opening



4. An acceptable detector location must ensure:

- Reliable igniter flame detection.
- Reliable main flame detection.
- Rejection of igniter flame too short or in the wrong position to ignite the main flame reliably, thus prohibiting main fuel admission.
- Clear line of sight to minimize visual direct sighting of opposite side burner flame (if applicable)



NOTICE: Reliable signals must be obtained at all air flows and furnace loads (ranges of fuel firing).

5. If combustion air enters the furnace with a rotational movement of sufficient velocity to deflect target flame in direction of rotation, position the detector 0 to 30° downstream of target flame and close to the periphery of the throat where the ultraviolet radiation is maximum, as shown in **Figure 6**.

Figure 6 - HD Detector Location vs. Secondary Air Rotation

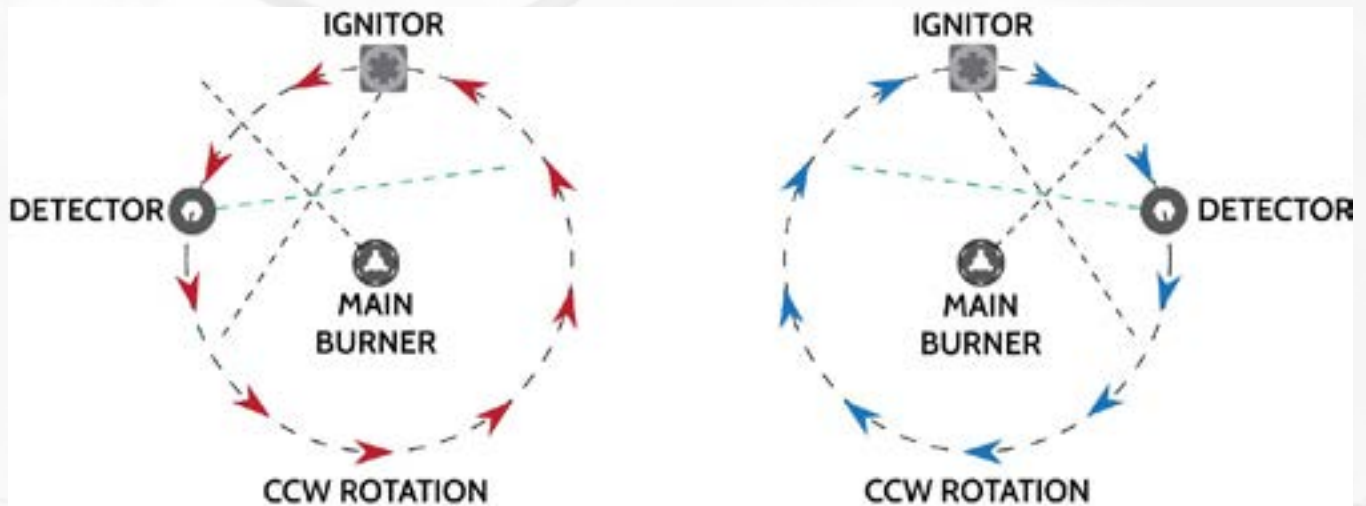

6. After determining an appropriate location of the sight tube, cut a clearance hole for a 2-inch pipe through the burner plate. If register vanes interfere with the desired line of sight, the interfering vane(s) should be trimmed to ensure an unobstructed viewing path at all firing levels.

7. The preferred method for installing front mounted detectors requires the use of a swivel mount (**Optional**), P/N 60-1664-3 (NPT), shown in **Figure 7**. Center the swivel mount over the two-inch hole in the burner plate and secure using three hexed cap screws. Install the sight pipe on the swivel mount. If a swivel is not used, insert the end of the sight pipe into the hole, align the hole to the desired viewing angle and tack weld (welding must be adequate to temporarily support the weight of the installed detector). The sight pipe should be arranged to slant downward so that dirt and dust will not collect inside and impede detector's sighting.

Figure 7 - Swivel Mount, Wye and Detector Assembly

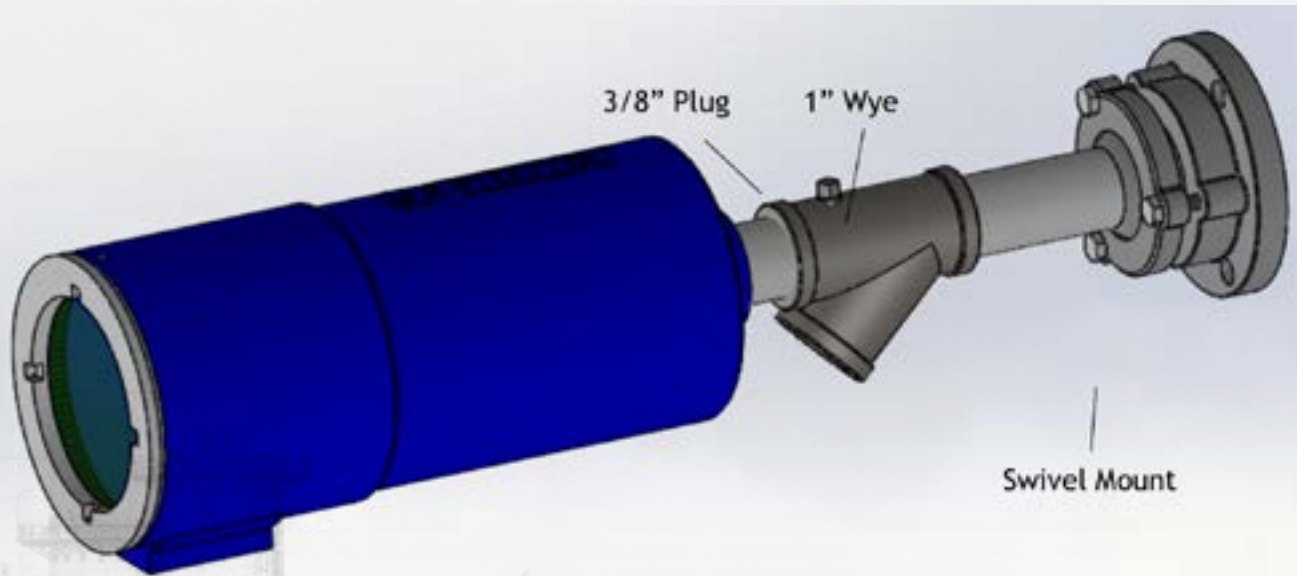

8. When a satisfactory sighting angle has been confirmed (by operational testing), secure the swivel mount's ball position in-place by tightening the three hex head cap screws located on the swivel mount ring.
9. For ease of use, the detector should be installed on the sight pipe, so the LED display can easily be read.
10. The detector lens must be kept free of contaminants (oil, ash, soot, and dirt) and the detector housing temperature must not exceed its maximum rating of 150° F (65° C). Both requirements may be satisfied by a continuous injection of purge air at the 1" wye connection downstream of the swivel mount as shown in **Figure 7**.



NOTICE: It is good practice to use the sealing coupling (P/N 41075301 (SS304) or 41075302 (SS316) NPT, 9114782 BSP) on all installations to ensure against unwanted furnace pressures from damaging the detector lens.

Under normal conditions, with clean burning fuels and moderate ambient temperature conditions, purge air flow of approximately 5 SCFM (141 l/min) is generally adequate. Up to 15 SCFM (425 l/min) may be required for fuels that produce high levels of ash or soot, or for hot environments to maintain the detector's internal temperature within specification.

2.4 WIRING

The HD Flame Detector is equipped with two Wire-to-Wire Poke Home type connectors designed ease of use in industrial wiring applications. This design allows the connectors to provide maximum wire retention for 18-24AWG solid and stranded wire gauges.

Wiring Instructions:

Check the Flame Detector has been mounted rigidly.

Remove the hexagonal set screw with the aid of 2mm Allen wrench (be careful not to lose), open the cover which is 124mm diameter.

Connect each wire to the position of Connectors matching the identical color wire.

Close cover tightly ensuring the O-ring shall be is not misplaced and tighten the hexagonal set screw.

Finally assemble the cable gland according the instruction provided by cable gland / entry device's supplier.

External earth having cross-sectional area more than 4mm² shall be properly connected. See below for the pin out diagram of the cable and two connectors.

Figure 8 - HD Detector Cable Wire Colors

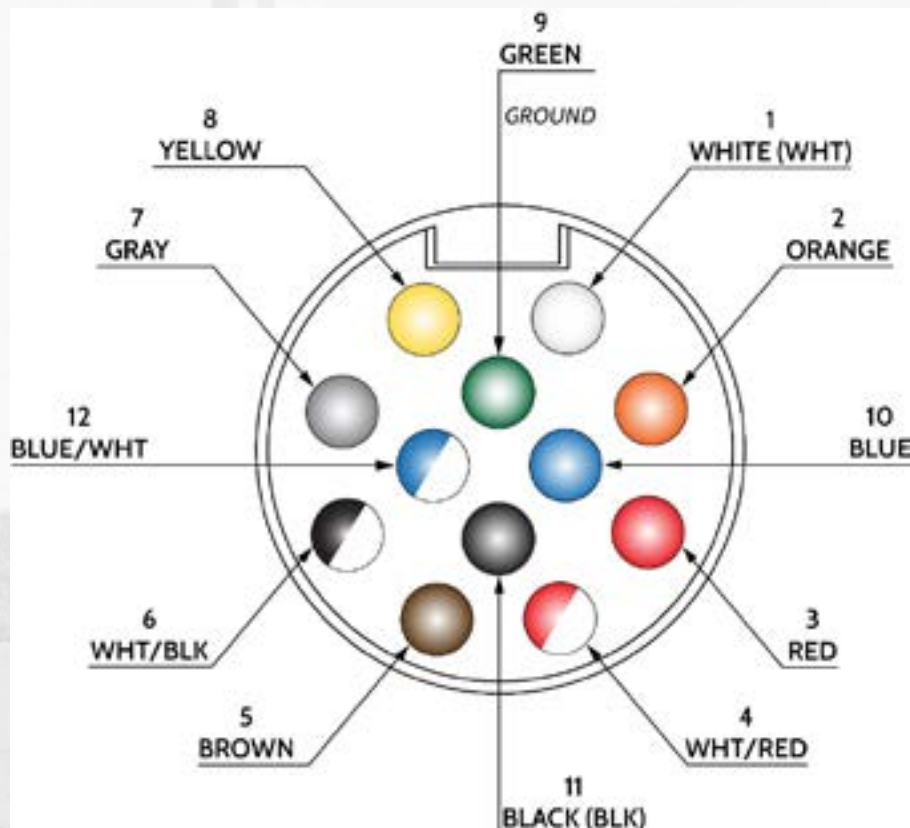
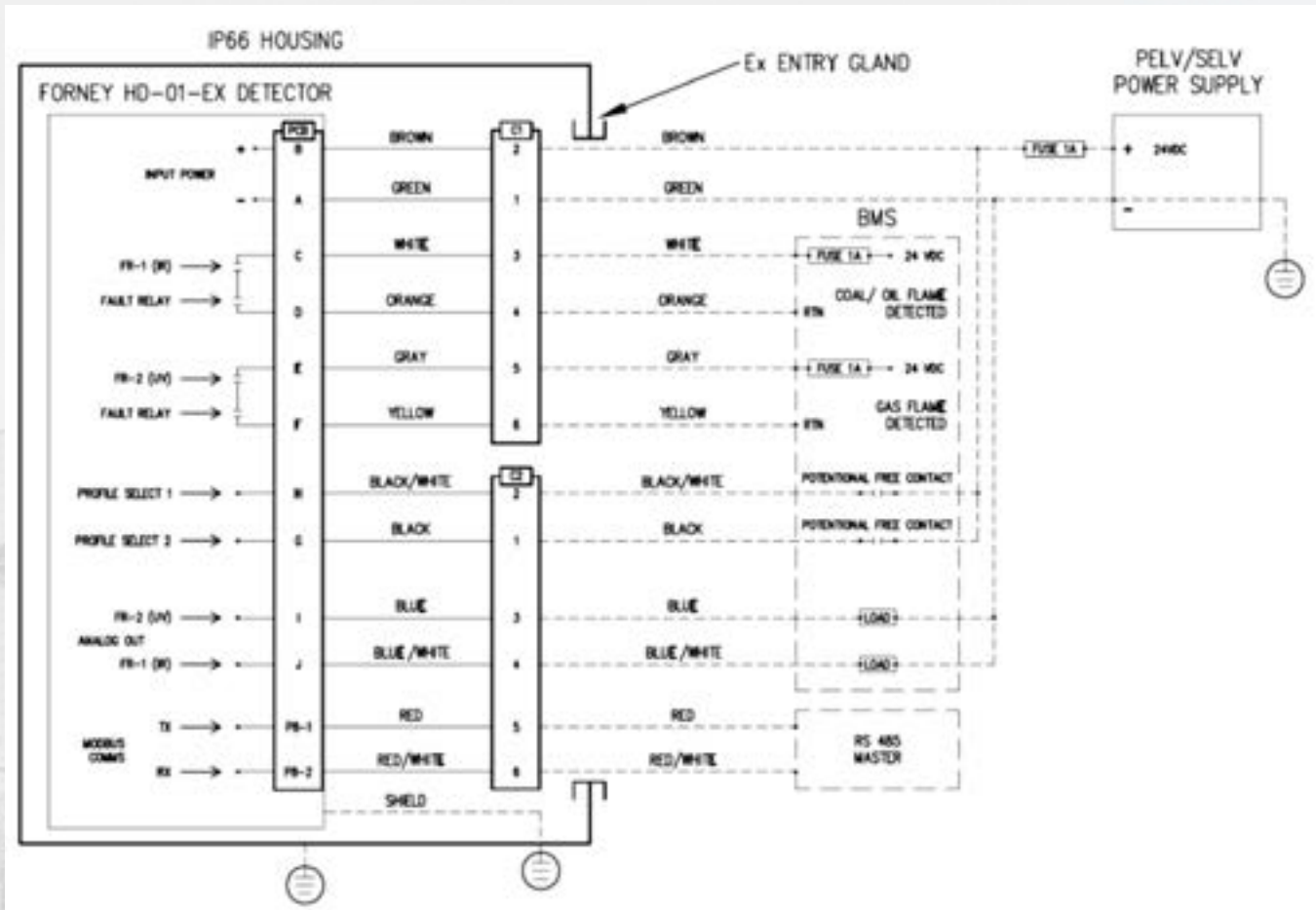

Figure 9 - Wiring Diagram



NOTICE:

- Fuses must be installed externally, as shown.
- Fault Relay contacts internally wired in series with Flame Relay Contact.
- Flame Relay contacts energize to “close” on detection of target burner flame.

2.4.1 Grounding and Shielding

1. Connect a safety ground to detector housing provided on the housing
2. The detector and detector cable **MUST** be located at least 12” away from the high-energy spark ignition source.

2.4.2 Communication Wiring

Forney HD Connect, a software for windows-based computers is available for monitoring and tuning the Forney HD Detector. Up to 32 detectors can be connected in a daisy chain as shown in Figure 10 for monitoring and tuning purposes. Connect the TX (or RX) wires of each detector to a common wire. The wire should then be connected to the TX (or RX) port the 485 adapter (Forney P/N: 9194898). The other end of the adapter can be connected to USB port serial port of the computer. If an installation has more than 32 HD Detectors, another daisy chain of 32 detectors will need to be connected to a different USB serial port of the computer.

Figure 10 – Daisy Chain for HD Flame Detectors

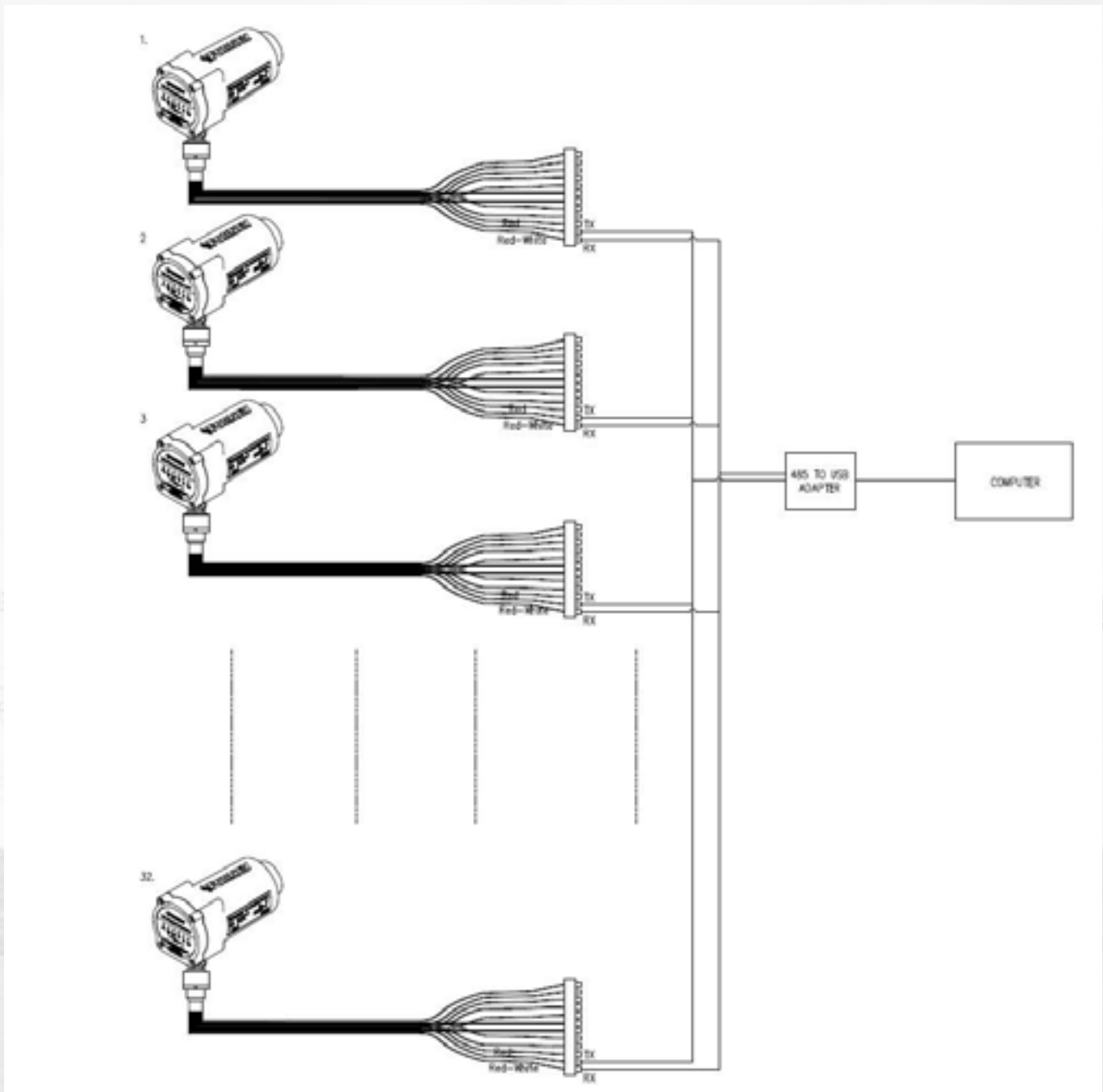

SECTION 3

SETUP AND CONFIGURATION

The purpose of this section is to ensure that the HD Flame Detector is properly setup and configured, using recommended Forney practices.

3.1 TUNING (Using Mobile App)

Upon completion of installation, turn on input power to the HD Detector. The Power LED will turn steady green; (if Bluetooth® is enabled) about 15 seconds later Bluetooth® LED (blue) will start flashing. Now HD is available for Bluetooth® connection to a mobile device using Forney App. If Bluetooth® is disabled, please refer to HD Connect Manual (Publication 372001-22) to tune the HD Detector.

Launch Forney App on your mobile device. All HD Detectors within proximity of mobile device and available for connection are displayed. Connect to the target HD Detector. Once a connection is established, Bluetooth® flashing light on the target HD Detector will turn steady blue. Before starting to tune, user must verify that Forney App is connected to correct target HD Detector.

The following steps are recommended for initial setup up the flame detector:

1. Tune mode requires a password; Factory Default password is 1234. The password can be changed to any desired 4-digit number, once in Tune mode. User should follow site specific policy to perform password change, as needed. Password can only be numeric values except 0000.
2. **Tuning mode:** Adjust gain to mid-scale value of approximately 125.
3. **Automatic Gain:** Set auto gain to “On”.
4. Flame Failure Response Time (FFRT): Set as required by local code. When in doubt, set FFRT to 1 second. Update the detector with new settings. Settings are saved to the HD Detector only on touching Update Detector button on tuning page of the App.
5. Go to the Monitor page to verify changes in steps 1 through 3 are active.
6. Start the target burner. Once flame is established, go to the spectrum screen to verify IR and UV sensors signal spectrum. Note the frequency bin where flame signal intensity is maximum.

7. **Preamp Gain** (1 through 255): Set range such that the main fundamental frequency is optimized without amplifying excessive background noise. Set Preamp gain to keep sensor signal value at around 600. Periodically sensor signal displayed on app will shoot up towards 1023 during sensor test. However, if sensor signal value remains at or near 1000, preamp gain must be reduced to avoid sensor saturation..
8. **Gain Trim Control**: Gain Trim Control is designed to adjust sensor sensitivity (Preamp Gain) such that sensor signal will be approx. midrange (600). Under dark furnace conditions, Gain Trim Control forces the preamplifier gain to a low value to avoid the gain drifting to maximum. When the target burner is off, gain control may increase the preamplifier gain where the detector may start to pick up background radiation from adjacent furnace background or opposed wall burners. In such instances, Gain Trim Control is recommended to be turned off after fine tuning to a required value.
9. **Gain Control** (1 through 255): Adjust gain so that optimum pulse count is achieved (0-1000) for satisfactory operation of flame pick up and drop out using the Spectrum page. If pulse count is seen to be at its maximum (1023), lower the gain marginally to avoid signal levels always railing high.
10. Turn off target burner or close the isolation valve on the sight tube to block any light coming to the flame detector. On multiple burner furnaces, its recommended to turn off the target burner for this step. Write down the highest frequency bin and flame signal intensity as recorded in step 5.
11. Go back to Tuning page and adjust frequency window 1 and 2 (if required) such that frequency bin where the highest flame signal was recorded in step 1 is within frequency window set points. For example, if high signal intensity was seen at frequency bin 30, frequency window 1 settings should be bin 26 to 36. If only one distinct signature setting is identified on a burner, ensure frequency window 2 settings are identical to frequency window 1 settings.
12. **Flame Relay Pick up and Drop out** (range 0-1023): Adjust flame relay pickup (PU) value at approximately 50% of the highest signal recorded in step 5. Flame Relay drop out (DU) value should be set near half of the pickup (PU) value. Update the detector with new settings.
13. Analog scaling (range integer value from 1 to 5): Adjust 4-20ma range to desired scaling. For example, 4ma at drop out set point and 20ma at 1000.

Device Settings

14. On first power up, each detector broadcasts itself by tag name starting with FCXXXX, where XXXX are the last 4 digits of the Serial Number of the device. User may assign the plant instrument ID to the HD Detector and save it for easy identification. Go to Tune tab on mobile App or Desktop Software and change Tag name under Device settings. Bluetooth connection will be lost when the detector is updated by clicking Change Tag button. It is recommended that users assign a Tag number prior to tuning the flame detection settings. Please note that the Tag number can be up to 6 character long Alpha-Numeric name but it cannot have any special characters such as \$, !, @ etc.

15. Factory default for Modbus slave address is last three digits of the serial number on the product label. It can be changed from the Tune tab on Mobile App or Desktop Software. For daisy-chained detector, slave ID must be unique for each HD Detector connected to the same RS-485 connector. However, two HD Detector on different RS-485 connector can have same Slave ID.

16. Settings are saved to the HD Detector only on pressing Update Detector button on Tuning page of the Mobile App or Desktop Software.

17. **Save Tuning**

a. Once an HD Flame Detector is connected via Bluetooth or 485 Modbus, its existing setting can be saved on mobile or desktop using the Save Tuning button in Tune Mode tab. Please note that the values on the left column(s) of ONLY FR1 and FR2 are saved while the values under Device Settings section are NOT saved.

b. Previously saved tunings can be uploaded from the mobile or desktop by clicking the on the left top corner of the mobile App or File -> Saved Tunings from the Desktop App. The App will redirect and populate the Tune Page to show these retrieved parameters from the encrypted file on mobile or desktop. These settings can then be uploaded to the connected HD Flame Detector by clicking Update Detector button. Please note that the previously saved tunings do NOT include Device Settings. Accordingly, these settings should be manually changed, if needed, prior to hitting Update Detector button. It will not change TAG number, however.

18. **Factory Reset:** The factory default button on Tune page restores the settings to factory default values. Please note Factory Reset will reset Modbus Slave ID to XXX where XXX are last 3 digits of the serial number, and Tune mode password to 1234.

19. **Reset Forgotten Password:** To reset a forgotten password, please contact Forney Service Department to request the unit specific password. Please provide last 5 digits of the unit Serial number and its six character Tag name when requesting reset password. Forney will generate a device specific password which can then be used to enter tune mode and reset the standard password to a desired password. A new device Specific Master Password may be required if lock out again in future.

20. **Modbus parameters:** HD-01 Flame detector can be connected to a laptop/computer using RS-485 connectors. The RS-485 parameters are as follows:

Baud Rate	Number of Data Bits	Number of Stop Bits	Parity
19200	8	1	None

3.2 MOBILE APP

The Forney App is a user-friendly tool used to monitor performance and tune the HD Flame detector. The app connects to the HD Flame Detector via Bluetooth® technology. Forney Publication No. 372001-21 describes features of the Mobile App.

3.3 DESKTOP APP

The Forney HD Connect Desktop software allows user to monitor several HD Flame Detectors simultaneously. The user can tune the HD Detectors by entering Tune mode for one HD Flame Detector at any time. Forney Publication No. 372001-22 describes features of the Desktop App.



WARNING: To ensure safe and reliable flame detection, it is the responsibility of the commissioning engineer to perform all flame failure testing after programming the detector. Ensure that the detector correctly detects the target flame (Flame “On” Condition) and recognizes the target flame off (Flame “Off” Condition).

3.4 BLUETOOTH ENABLE/DISABLE

Please refer to Section # in Forney Publication 372001-22 to enable/disable Bluetooth®, if required.

SECTION 4

SERVICE AND TROUBLESHOOTING

This section reviews general service and provides basic guidelines for handling and storage of the equipment.

4.1 SERVICE

Coordination

Performing service on this equipment could impact more personnel (plant, yard, etc.) than just those that maintain this equipment. Therefore, it is advisable to get approval from site-leading personnel prior to performing service on this equipment.

Handling

The HD Detector consists of delicate electronic circuitry. Therefore, it is advisable to discharge any “static” electricity prior to handling the unit. Additionally, the HD Detector should be handled delicately, without aggressive bumping, dropping, etc.

Storage

It may be necessary to remove this equipment from service for extended periods of time. The HD Flame Detector should be stored in its shipping box. See section 1.3 Technical Specifications for storage temperature and humidity ranges. Normal static precautions should also be taken in handling parts sensitive to electrostatic discharge (ESD).

Regular visual inspections should occur to ensure they are continuously protected from the harsh elements during storage.

4.2 TROUBLESHOOTING

If the flame detection system fails, isolate the fault to the flame detector and the cable between the detector, and the cable. The following instructions provide general guideline for fault isolation:

1. If the Fault LED is lit, cycle power to the detector to reset the detector. Connect to the detector via Forney App, and go to Alarm page to see reason for last recorded failure. Use Clear Alarm button to clear alarm history.
2. If the High Temp LED is solid red, then disconnect the detector and wait for it to cool down before powering it back on. Probable cause of high detector temperature is loss of purge air supply, leakage of hot gases from the furnace or coal pipes near the detector location, damaged insulation on furnace wall, or internal failure.
3. If all LEDs are flashing, reboot the detector by switching off input power and turning it back on after 10 seconds. Do not use quick disconnect on cable for cycling power off/on.
4. If no LED is lit, measure the power inputs to verify input power is present within its specified range.
5. If restart does not resolve the problem, remove power from the system and check for open fuses. Replace open fuses as required. If the problem persists, contact Aftermarket Department at Forney for replacement, return the HD Flame Detector to Forney for repair/replacement.

Table 2 - Troubleshooting

Symptom	Indicator	Possible Cause	Remedy
Fault LED on	Temperature Hi LED On	Internal Temperature High	Inadequate purge air, damaged insulation on furnace wall, leakage of hot air / gases around detector, air circulation blocked around detector location, damaged electronics, high ambient temperature.
Does not detect flame		Poor sighting	Remove HD to verify flame can be sighted through the mounting location.
		High Gain or PreAmp Gain	High Gain or PreAmp Gain settings may saturate the signals (values > 1000). Reduce Gain.
		Sensor Saturation	Use orifice to reduce amount of radiations reaching lens.
Frequent Watch Dog Failures or Chirping Flame Relay	Flame Relay chirps or Detector shows Watch Dog	Radio Frequency by a cable of a Motor/Switch/ Noise-Source	Install Detector away from any possible noise source
		Detector not properly grounded	Ground the detector to a clean ground (instrument ground if possible).
		High Temperature	Install Detector away from potential temperature sources. Use Fiber Optics if needed and/or use Cooling Jacket as needed.

SECTION 5

AFTERMARKET

5.1 RMA/Warranty

Forney Corporation and Woochang Electric warrant this product to be free of defective material and workmanship. Forney and Woochang will replace this equipment as long as it is being used for its intended use and is found to be defective upon receipt up to the expiration of the warranty period.

Prior to returning any material to us, please contact Woochang and Forney's Aftermarket Department and provide the contract number or the customer purchase order number.

5.2 Parts and Accessories

To order HD Flame Detectors or associated equipment, contact Forney's Aftermarket Department via any one of the following methods and furnish the following information.

Email	Phone	Fax
spares@forneycorp.com	972-458-6100 or 972-458-6142 or 1-800-356-7740 (24-hour direct line)	972-458-6600

1. Contract number
2. Customer purchase order number
3. For each part ordered, provide the following information:
 - a. Part number*
 - b. Part description*
 - c. Quantity required

* Refer to Section 1.4 of this manual for part numbers and descriptions

5.3 Enclosure

The enclosure is manufactured by Woochang Electric. If you need data about enclosure, please refer to following information.

Email	Phone	Fax
wcel@woochang.co.kr	82 31 769 2136	82 31 769 0138



NOTICE: Forney is NOT responsible for materials returned without proper authorization and identification. Exercise care in packing the materials/units to be returned. The shipper will be advised of any damage due to improper packing and no further action will be taken in connection with this material return until the shipper provides clearance for further disposition.



NOTICE: Prices and specifications are subject to change without notice.

SECTION 6

APPENDIX

6.1 COMMON ACRONYMS

A	Amps
AWG	American Wire Gauge
BAS	Building Automation System
BMS	Building Management System
CW/CWW	Clockwise / Counter-Clockwise
DCS	Distributed Control System
ELV	Extra Low Voltage
ESD	Emergency Shut-Down
ESD	Electrostatic Discharge
FO	Fiber Optics
FR	Flame Relay
HD	High Definition
Hz	Hertz
IP	Ingress Protection
IR	Infrared
kHz	Kilohertz
LED	Light Emitting Diode
mA	Milliampere
NPT	National Pipe Thread
NPTF	National Pipe Thread Fine
OEM	Original Equipment Manufacturer
P/N	Part Number
PLTC-ER	Power Limited Tray Cable - Exposed Run
PSI	Pound (of force) per Square Inch
PTFE	Poly(tetrafluoroethylene) = Teflon
PVC	Polyvinyl Chloride
RMA	Return Material Authorization
SCFM	Standard Cubic Feet per Minute
SELV	Safety Extra Low Voltage
UNC	Unified National Coarse
UNF	Unified National Fine
UV	Ultraviolet
VAC	Volts of Alternating Current
VDC	Volts Direct Current

6.2 COMMON REGULATORY AGENCIES

ANSI	American National Standards Institute
API	American Petroleum Institute
ASME	American Society of Mechanical Engineers
ASTM	American Society for Testing and Materials
ATEX	Atmosphere Explosibles (EU) Explosive Atmosphere
CE	Conformité Européenne (European Conformity)
CEC	Canadian Electrical Code
EN	European Norm
EOTA	European Organization for Technical Assessment
FM	Factory Mutual (Approval)
IEC	International Electro-Technical Commission
ISO	International Organization for Standardization
NEC	National Electrical Code
NEMA	National Electrical Manufacturers Association
NRTL	Nationally Recognized Testing Laboratory
OSHA	Occupational Safety Health Administration
UL	Underwriters Laboratories



IECEX Certificate of Conformity

INTERNATIONAL ELECTROTECHNICAL COMMISSION IEC Certification System for Explosive Atmospheres

for rules and details of the IECEX Scheme visit www.ieceex.com

Certificate No.:	IECEX KGS 21.0002X	Page 1 of 3	Certificate history
Status:	Current	Issue No: 0	
Date of issue:	2021-03-02		
Applicant:	WOCHANG ELECTRIC CO., LTD. 14-11, 14-13, 14-10 Mugap-gil 140beon-gil, Chwol-eup Gwangju-si, Gyeonggi-do 12730 Korea, Republic of		
Equipment:	HD Flame Detector / Model : Forney-HD-01-EX		
Optional accessory:			
Type of Protection:	Ex db		
Marking:	Ex db IIC T6 Gb, IP66		

Approved for issue on behalf of the IECEX
Certification Body:

Seogkwon Chu

Position:

General Manager

Signature:
(for printed version)

Date:

2021. 3. 7

1. This certificate and schedule may only be reproduced in full.
2. This certificate is not transferable and remains the property of the issuing body.
3. The Status and authenticity of this certificate may be verified by visiting www.ieceex.com or use of this QR Code.



Certificate issued by:

Korea Gas Safety Corporation
1390 Wonjung-ro
Maengdong-myeon
Bumseong-gun
Chungcheongbuk-do
27738
Korea, Republic of



**KOREA GAS SAFETY
CORPORATION**