

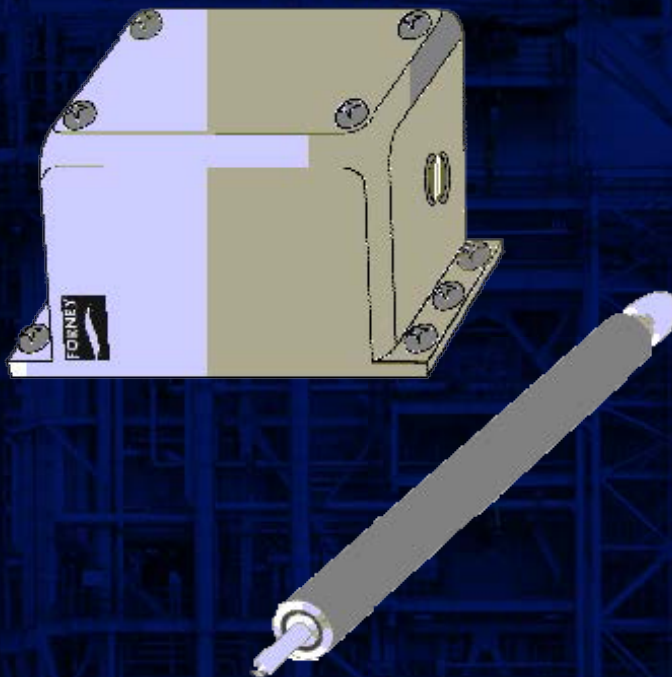

High Tension Spark Igniter (HTSI) User Manual

Publication 372000-55 Rev D

● BURNERS ● IGNITERS ● DAMPERS ● CONTROLS



www.forneycorp.com

INTRODUCTION

This manual contains information for the High Tension Spark Igniter (HTSI) from Forney Corporation, 16479 North Dallas Parkway, Suite 213 Addison, TX 75001.

All personnel should become thoroughly familiar with the contents of this manual before attempting to install, operate or maintain a HTSI. Because it is virtually impossible to cover every situation that might occur during operation and maintenance of the equipment described in this publication, personnel are expected to use good engineering judgment when confronted with situations that are not specifically mentioned herein.

The user should update this manual whenever significant changes are made to the system. To be of value, the manual must always reflect the latest configuration of the equipment. It should be noted, however, that Forney Corporation will furnish updated pages only if Forney authorizes a modification and accomplished under Forney supervision.

PROPRIETARY NOTICE

The contents of this publication are proprietary data of Forney Corporation. Reproduction or use of any part of the publication for purposes other than the support of the equipment for which it is published is permissible only if expressly authorized in writing by Forney.

Additional copies of this publication may be purchased from Forney. When ordering or requesting cost information, refer to the publication number appearing on the title page. Address to the attention of the Sales Department, Forney Corporation, 16479 North Dallas Parkway, Suite 600 Addison, TX 75001.

REVISIONS

REVISIONS	DATE	COMMENTS
A	10/2004	Initial Release
B	10/2011	Remove cable assemblies longer than 180"
C	09/2015	Update addresses and logos
D	08/2020	

TABLE OF CONTENTS



TABLE OF CONTENTS

<u>Section 1 Description</u>	1
<u>Section 2 Specifications</u>	2
2.1 Dimensions	3
<u>Section 3 Operation</u>	4
<u>Section 4 Application</u>	5
<u>Section 5 Installation</u>	6
<u>Section 6 Commissioning</u>	7
<u>Section 7 Troubleshooting</u>	8
<u>Section 8 Maintenance</u>	9
<u>Section 9 Storage</u>	10
<u>Section 10 Return or Repair Service</u>	11
<u>Section 11 Ordering Guidelines</u>	12
11.1 Spare Parts	15

SECTION 1

DESCRIPTION

Forney's High Tension Spark Igniter (HTSI) system is designed to provide a spark ignition source for gas-fired pilots and igniters. The HTSI consists of a high tension spark rod with spark plug style cable connector, pre-fabricated high voltage cable and a 6,000 VAC transformer.

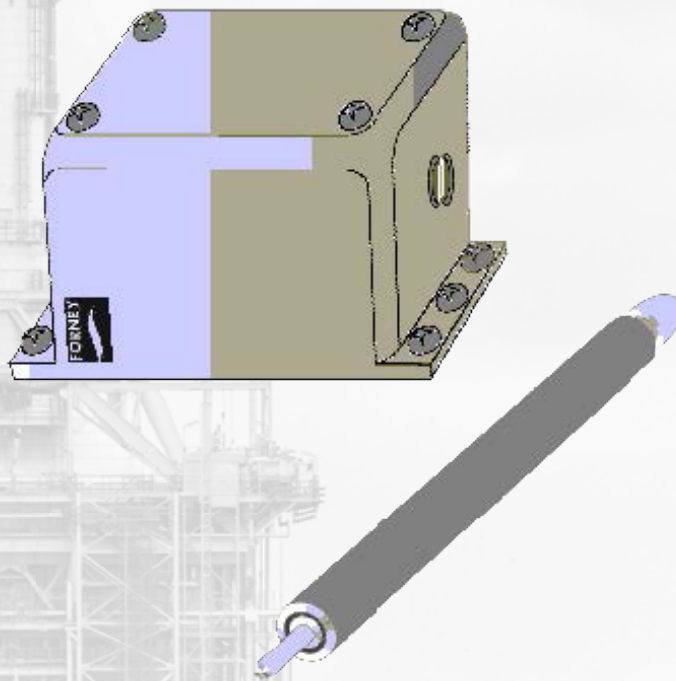

Forney's HTSI spark rod was designed to eliminate the traditional practice of adjusting the spark electrode with the ground surface. The spark rod tip employs a center electrode with a pre-defined distance from the ground surface, ensuring proper spark gap distance at all times.

Forney's HTSI spark rod utilizes state of the art high temperature polymers, designed to prevent the spark from grounding out prematurely to the rod casing and eliminate cracking of insulation. The tip insulation is ceramic due to high temperatures.

The HTSI rod is not maintainable, and should be discarded if it fails.

SECTION 2

SPECIFICATIONS

General	
Igniter Class:	Class 3 Special
Output Voltage:	6,000 VAC
Input Voltage:	115 VAC /230 VAC 50/60Hz
Spark Rate:	Continuous High Tension
Spark Rod	
Spark Rod Material:	Stainless Steel
Spark Rod Length:	14" to 180" (457.2 cm) Maximum
Spark Rod Diameter:	0.625" (1.6 cm)
Spark Tip Type:	Fixed Gap
Spark Tip Length:	Non-Removable, Fixed to Spark Rod
Spark Tip Resistance:	Open Circuit When Not Firing
Max Tip Temperature:	1000°F (537°C)
Cable	
Power Cable:	Insulated 18 Gauge, 10kV
Cable Lengths:	240" (609.6 cm) Maximum
Duty Cycle:	100% at Temperature Rating
Transformer	
Output Connection:	Single Pole
Max Temp:	-40°F to 105°F (-40°C to 40°C)
Weight:	9 pounds (4.1kg)
Rating:	NEMA 1 (IP30)
Dimensions:	6.75" x 4.438" x 4.313" (17.15 cm x 11.28 cm x 10.96 cm)
Mount Holes:	6" x 2.5" (15.24 cm x 6.35 cm);

2.1 DIMENSIONS

Figure 1 HTSI Dimensions

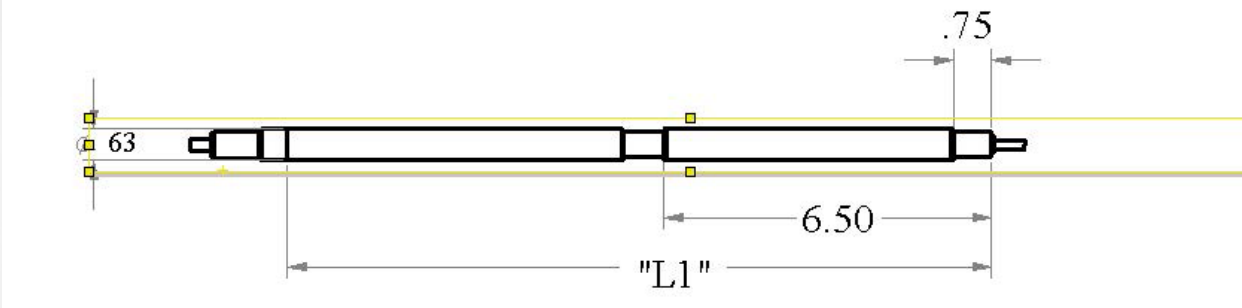

SECTION 3

OPERATION

The HTSI assembly is a “Class 3 Special” ignition source as defined by NFPA and is only in service during the trial for ignition.

The burner management system provides the control signal that energizes the HTSI during the trial for ignition. The transformer converts the primary 115 V or 230 V to a secondary output of 6,000 V. The high voltage cable assembly carries the secondary voltage to the rod. The rod then is designed to prevent the spark from grounding out to the metallic rod casing until the voltage reaches the center electrode tip. The voltage then discharges to the outer casing of the spark rod and provides a continuous high voltage discharge, with sufficient temperature for lighting off the proper fuel air mixture.

SECTION 4

APPLICATION

High tension ignition is suitable for such fuels as natural gas, propane or similar gaseous fuels. Forney's HTSI is best used to light off a pilot flame, where the pilot flame is used to light off the main burner flame.

As with any high tension application where moisture is present, such as turbine exhaust gas, process off gases, or steam atomization, the moisture can cause the spark from a high tension igniter to quench and possibly fail the light off. For such applications, Forney offers high energy spark ignition (HESI) to provide assured ignition energy (see publication 384077-02).

The HTSI is not recommended for use with liquid fuels.

SECTION 5

INSTALLATION

Spark Rod

In most cases, the HTSI spark rod fits into a guide tube that houses the spark rod assembly. Observe the following steps for installing the spark rod assembly:

1. Carefully insert the spark tip into a guide tube until the spark rod extends into the primary ignition zone.
As a general guideline, position the spark tip flush with the baffle plate for gas igniters.
2. Once the tip penetration is set, mark, attach and tighten the locking device to the spark rod.
3. When a retraction assembly is supplied, exercise the retraction cylinder, either manually or automatically, in extend and retract positions to check for correct operation.

Cable Assembly

Observe the following steps for installing the cable assembly:

1. Connect the cable assembly with the ring lug end to the screw fastener on the secondary pole of the transformer and tighten.
2. Secure the female spark plug style connector from the cable assembly on the male spark plug connector on the spark rod assembly.

Transformer

Observe the following steps for installing the high voltage transformer:

1. Locate the transformer from extreme temperatures and within a reasonable distance from or on the burner front plate. Allow enough cable length for retraction and boiler expansion.
2. Mount the transformer with fasteners through the four mounting holes. Ensure that the cable connector is facing up (secondary voltage post upright position) to avoid accumulation of dust or liquid into the primary voltage wiring chamber of the transformer.

Power

Observe the following steps for installing the power to the transformer:

1. Connect power input leads from BMS to black wires on transformer for H (Hot) and N (neutral).
2. Ensure that the transformer shares a common ground return path with the burner steel. Secondary of transformer is grounded to casing.

SECTION 6

COMMISSIONING

When installation is completed, perform a spark test and observe the spark rod operation in the following manner:

1. With the HTSI rod in the guide tube, energize the transformer by applying proper voltage and observe the operation of the tip.
2. If the spark can not be observed in place, mark the HTSI rod at the original position and remove from the guide tube. Place the rod in a safe location to ensure spark tip is not in a position to cause harm or ignite flammable items. Ensure the outer tube or rod is grounded.
3. Energize the transformer by applying proper voltage to the transformer.
4. Observe the spark at the tip of the spark rod. If spark did not appear, then check with a voltmeter to make sure the proper primary voltage is applied. If primary voltage is properly applied, then de-energize the transformer and ensure that the cable assembly is secured to the transformer and spark rod assembly.
5. If spark is present, then de-energize the transformer and re-insert into guide tube at the original position.
6. With the HTSI working properly, energize the system to observe performance with its associated fuel. Check to ensure proper fuel pressure and combustion air flow are applied (refer to the appropriate igniter service manual for pressure and flow specifications). If the HTSI system functions properly and the igniter fails to light off, reposition the spark rod so that the spark is properly delivered to the fuel.
7. When repositioning the HTSI rod, start from the current location and move the rod inward 0.5 inches (1.3 cm). Retest with fuel and note performance. Continue to move the HTSI rod inward or outward 0.5 inches (1.3cm) per test. Do not move rod more than 3 inches (7.6 cm) in either direction.

SECTION 7

TROUBLESHOOTING

If the HTSI malfunctions, ensure that the procedures listed in the Commissioning section have been performed successfully.

If problems continue to occur, refer to the table listed below for troubleshooting information. This table describes the symptoms, probable causes and possible solution for particular malfunctions.

Symptom	Probable Cause	Possible Solution
HTSI not sparking at tip	Input voltage not correct	Supply proper voltage
	Secondary voltage not reaching the rod	Tighten the spark plug style connector on the rod or replace the cable assembly
	Secondary voltage not correct	Replace transformer
	Spark tip is fouled	Clean rod tip and electrode as described in Maintenance section.
	Tip insulator is damaged	Replace spark rod
	High tension cable inside rod damaged.	Replace spark rod
	Internally grounded.	Replace spark rod
HTSI has a weak or erratic spark at tip	Vibration from burner causing intermittent contact of cable connections	Tighten the connections of the cable assembly at transformer and rod assembly ends
	Insulation of cable assembly damaged	Replace cable assembly
	Short circuit at tip	Bend rod casing tip to uniform circumference from center electrode

SECTION 8

MAINTENANCE

Forney recommends performing the following preventative maintenance every six months.

HTSI Rod Assembly

With the transformer de-energized, mark the rod location and remove from guide tube.

1. Inspect the center electrode for oxidation, oil, dirt, or grease build up. Clean surface with de-natured alcohol or lightly polish surface with 220 grain sandpaper.
2. Inspect the length of the rod for warped or crimped surfaces, to ensure rod is straight for proper insertion and delivery of spark.
3. Inspect rod tip to ensure casing is uniformly distant from center electrode.

Cable Assembly

Inspect cable for fraying, crimped or damaged insulation.

Transformer

With transformer de-energized:

1. Ensure that all interconnecting cable terminations are tight and secure.
2. Ensure that all interconnecting cable termination points are clean and clear of oxidation, oil, dirt, or grease.

SECTION 9

STORAGE

Store the HTSI igniter in a clean, dry atmosphere. When possible, store the assembly in its original shipping container until used. If the HTSI igniter is removed from its shipping container, store it in a horizontal position supported at both ends of the guide tube. Protect both guide tube ends from damage due to inadvertent bumps or blows. Cover the HTSI with plastic to keep it free of dust and dirt. Storage longer than 30 days requires humidity less than 85% and temperature less than 120 degrees Fahrenheit.

SECTION 10

RETURN OR REPAIR SERVICE

Forney Corporation warrants this product to be free of defective material and workmanship. Forney will repair or replace this equipment if it is found to be defective upon receipt, but not later than 90 days from the date of shipment.

Prior to returning any material to Forney, a Return Material Authorization (RMA) identification number must be obtained from Forney. Clearly mark the RMA number on all shipping containers and accompanying documents. Forney accepts only materials submitted in accordance with these RMA instructions.

To issue an RMA, Forney must have the following information:

- List of equipment to be returned by stock number/model number.
- Reason for return.
- Company name and address of the customer.
- Customer's requested mode for return shipping.
- Customer's purchase order number for repairs (if applicable).
- Customer's requested return date.
- Name and address to which Forney is to return-ship and any special container marking information that may be required.
- Name of individual (customer's representative) requesting the RMA.

Any one of the following methods may be used to obtain an RMA:

1. Phone: (972) 458-6100 or 458-6142
1-800-356-7740 (24-hour Emergency Line)
2. Fax: (972) 458-6600

FORNEY CORPORATION IS NOT RESPONSIBLE FOR MATERIALS RETURNED WITHOUT PROPER AUTHORIZATION AND IDENTIFICATION.

Exercise care in packing the materials to be returned. The shipper will be advised of any damage due to improper packing, and no further action will be taken in connection with this material return until the shipper provides clearance for further disposition.

SECTION 11

ORDERING GUIDELINES

Three steps to ordering the HTSI:

1. Select the length of the HTSI spark rod assembly
2. Select the length of the cable assembly
3. Select the primary voltage of the transformer

HTSI Spark Rod Assembly

(Part number system based on 2-inch increments)

Part Number	Length (L1)	Part Number	Length (L1)
369310-01	14" (35.56 cm)	369310-31	74" (187.96 cm)
369310-02	16" (40.64 cm)	369310-32	76" (193.04 cm)
369310-03	18" (45.72 cm)	369310-33	78" (198.12 cm)
369310-04	20" (50.80 cm)	369310-34	80" (203.20 cm)
369310-05	22" (55.88 cm)	369310-35	82" (208.28 cm)
369310-06	24" (60.96 cm)	369310-36	84" (213.36 cm)
369310-07	26" (66.04 cm)	369310-37	86" (218.44 cm)
369310-08	28" (71.12 cm)	369310-38	88" (223.52 cm)
369310-09	30" (76.20 cm)	369310-39	90" (228.60 cm)
369310-10	32" (81.28 cm)	369310-40	92" (233.68 cm)
369310-11	34" (86.36 cm)	369310-41	94" (238.76 cm)
369310-12	36" (91.44 cm)	369310-42	96" (243.84 cm)
369310-13	38" (96.52 cm)	369310-43	98" (248.92 cm)
369310-14	40" (101.60 cm)	369310-44	100" (254.00 cm)
369310-15	42" (106.68 cm)	369310-45	102" (259.08 cm)

Part Number	Length (L1)	Part Number	Length (L1)
369310-16	44" (111.76cm)	369310-46	104" (264.16 cm)
369310-17	46" (116.84 cm)	369310-47	106" (269.24 cm)
369310-18	48" (121.92 cm)	369310-48	108" (274.32 cm)
369310-19	50" (127.00 cm)	369310-49	110" (279.40 cm)
369310-20	52" (132.08 cm)	369310-50	112" (284.48 cm)
369310-21	54" (137.16 cm)	369310-51	114" (289.56 cm)
369310-22	56" (142.24 cm)	369310-52	116" (294.64 cm)
369310-23	58" (147.32 cm)	369310-53	118" (299.72 cm)
369310-24	60" (152.40 cm)	369310-54	120" (304.80 cm)
369310-25	62" (157.48 cm)	369310-55	122" (309.88 cm)
369310-26	64" (162.56 cm)	369310-56	124" (314.96 cm)
369310-27	66" (167.64 cm)	369310-57	126" (320.04 cm)
369310-28	68" (172.72 cm)	369310-58	128" (325.12 cm)
369310-29	70" (177.80 cm)	369310-59	130" (330.20 cm)
369310-30	72" (182.88 cm)	369310-60	132" (335.28 cm)

Cable Assembly

(Part number system based on 1-foot increments)

Part Number	Length (L1)	Part Number	Length (L1)
399632-01	12" (30.48 cm)	399632-09	108" (274.32 cm)
399632-02	24" (60.96 cm)	399632-10	120" (304.80 cm)
399632-03	36" (91.44 cm)	399632-11	132" (335.28 cm)
399632-04	48" (121.92 cm)	399632-12	144" (365.76 cm)
399632-05	60" (152.40 cm)	399632-13	156" (396.24 cm)
399632-06	72" (182.88 cm)	399632-14	168" (426.72 cm)
399632-07	84" (213.36 cm)	399632-15	180" (457.20 cm)
399632-08	96" (243.84 cm)		

Transformer

Part Number	Primary Voltage	Secondary Voltage
76638-00	110 V, 50 Hz	6,000 V
76638-01	220 V, 50 Hz	6,000 V
76638-02	120 V, 60 Hz	6,000 V

Note:

1. For lengths not shown, please consult factory for customer requirement.
2. The use of a two pole 10kVac transformer will not work with the HTSI rod.

Mount Tube

Mount Tube	Part #370311-XX
Mount tube with retraction	Part #389081-XX Consult Forney

11.1 SPARE PARTS

When ordering spare parts, contact Forney's Spares Department via any one of the following methods and furnish the following information.

Mail	Phone	Fax
Attn: Spare Parts Forney Corporation 16479 North Dallas Parkway Suite 213 Addison, TX 75001	(972) 458-6100 or (972) 458-6142 or 1-800-356-7740 (24-hour direct line)	(972) 458-6600

1. Contract number
2. Customer purchase order number
3. For each part ordered, provide the following information:
 - a. Part number
 - b. Part description
 - c. Quantity required

It is recommended that for every 10 igniters, 1 spark rod be maintained as a spare.