

# Double Block & Vent Valve Assembly

*Forney's Double Block & Vent Valve Assembly incorporates an integrated, compact design to deliver safe and reliable positive shut-off of gaseous fuels in burners and igniters.*

## Product Overview

The Forney Double Block & Vent Valve Assemblies are designed to conform to the latest NFPA suggested practice for gas fired boilers. A DBV Valve Assembly substantially reduces the cost of installation when compared to the installation cost of the separate valve and actuators.

The Double Block & Vent Valve Assembly consists of two block valves, a single pneumatic actuator, a ball type vent valve (size per NFPA guidelines), pipe spool, and limit switches. The two block valves are piped in series and driven by a common pneumatic actuator. Piping sizes up to two inches use ball type block valves, while piping three inches and larger use butterfly valves. The vent valve is piped from the spool between the two block valves and is also driven by a common pneumatic actuator. The vent valve is opened whenever the block valves are closed, and closed whenever the block valves are opened.

Limit switch is actuated by the actuator drive shaft providing positive valve position feedback. The limit switch and actuator control solenoid valve are pre-wired to a terminal strip in the limit switch enclosure, providing for easy external wiring installation and interface.

Standard Valve Operation is Fail Safe (FS) - spring return actuator with single coil solenoid (Block valves close and vent valve opens on loss air and/or voltage.) This meets NFPA recommendations.

## Features & Benefits

- **RELIABLE OPERATION**  
The Double Block & Vent Valve Assembly uses industry-proven components in an easy to maintain package.
- **COMPACT DESIGN**  
The Double Block & Vent Assembly takes up less space than multiple valve arrangements.
- **EASY INSTALLATION**  
The Double Block & Vent Assembly comes fully assembled and factory tested. No pre-operational adjustments are unnecessary. External electrical connections are made in the pre-wired limit switch enclosure.
- **DESIGNED FOR LONG LIFE**  
The heavy-duty design ensures a long, trouble free, operating life span.
- **MEETS NFPA GUIDELINES**  
Consult Forney for proper sizing and pressure ratings.



# Double Block & Vent Valve Assembly

Pub # 404006-14  
Rev 11/2011

## Specifications

Valve Sizes:	¾, 1, 1 ½, 2, 3, 4, 6 inches
Block Valve Type:	Ball (¾, 1, 1 ½ and 2 inch sizes) Butterfly (3, 4, and 6 inch sizes)
Vent Valve Type:	Ball (size per NFPA guidelines)
Actuation:	Pneumatic spring return standard
Actuation Solenoid Valve:	Single coil standard
Air Pressure:	60-120 psig @ 0°F – 212°F standard spring set designed for 60 psig
Voltages:	120 VAC, 60 Hz; 110 VAC, 50 Hz 240 VAC, 60 Hz; 220 VAC, 50 Hz Other voltages are available upon request
Limit Switches	DPDT; open and close position Limit switch housing doubles as junction box
Block Valve Connections:	¾, 1, 1 ½ and 2 inch valves, butt-weld, socket weld, or 150 # flanged 3 inches and above, 150# flanges
Vent Valve Connections:	Butt-weld, socket weld, or 150 # flanged

Consult Forney for proper sizing and pressure ratings.

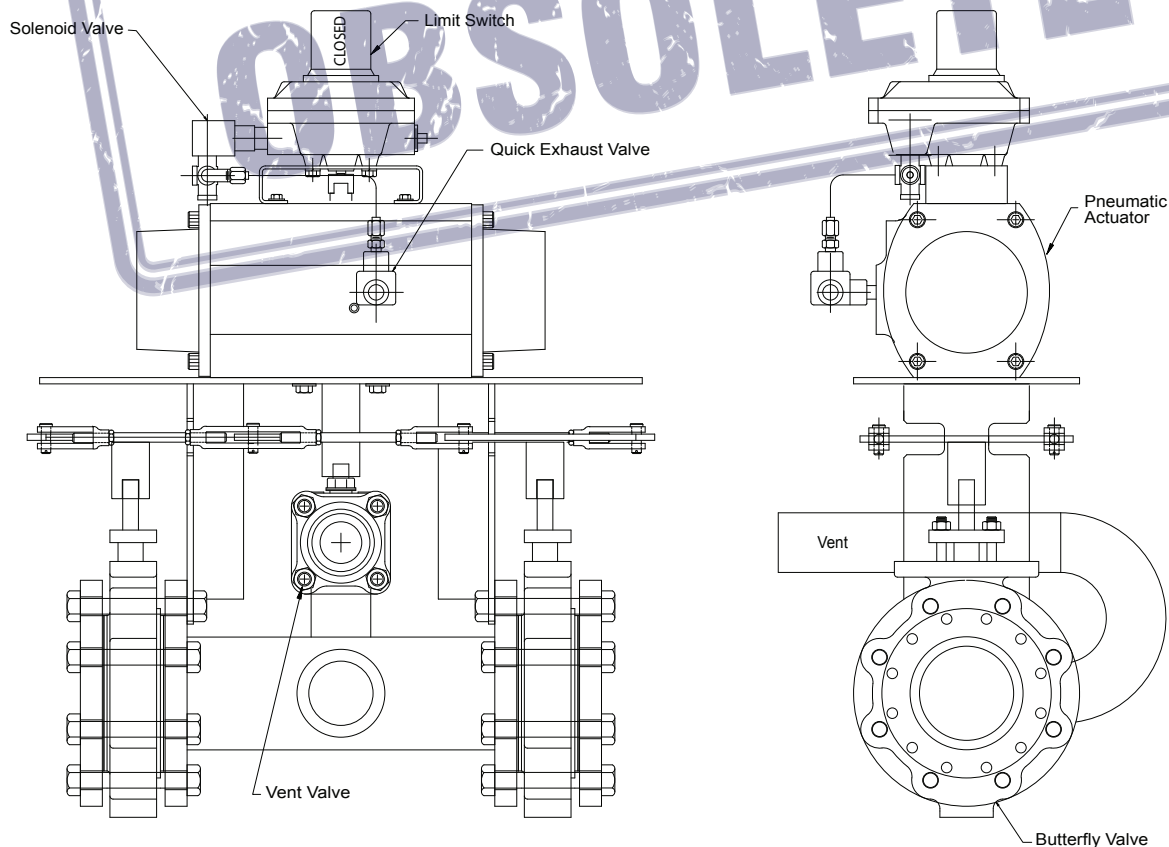

**Forney Corporation**

16479 North Dallas Parkway, Suite 600 • Addison, TX 75001  
800-356-7740 • Fax 972-458-6650 • [www.forneycorp.com](http://www.forneycorp.com)