

Quad Valve™ Assembly

Forney's Quad Valve™ Assembly is a self-contained system that combines safety shut-off valve and purge valve operations into a single, compact, easy-to-install unit providing years of trouble-free operation under the harshest burner front conditions.

Product Overview

The Quad Valve™ Assembly is a unique design that combines durability with ease of maintenance. The heart of the design is a series of four ball valves bolted between two heavy-duty steel manifolds. The top and bottom valves are connected with a four-bar linkage and operated by the “OPEN” actuator. The two inside valves are also connected in the same manner and are operated by the “PURGE” actuator. Both actuators are interlocked to allow the valves to progress through the three operating positions - “CLOSED”, “OPEN”, and “PURGE”. The combination of two independent actuators and four separate valves prevents contamination of the atomization media and out-of-sequence valve operation.

Installation of the Quad Valve™ Assembly is simplified both electrically and mechanically from other valves assemblies. Single-point electrical connections are made to terminal blocks inside the junction box that is on top of the valve assembly. Pipe connections for the oil and atomizing media are available in three different forms, socket weld, flanged, or plain pipe. The air supply for the pneumatic actuators is connected to integrally mounted solenoids, eliminating the need for external tubing that can become damaged or fail during operation.

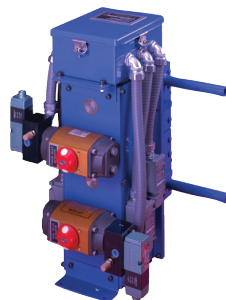

Features & Benefits

- **RELIABLE OPERATION**

The Quad Valve™ uses industry-proven components in an easy to maintain package.

- **LOW PRESSURE DROP**

Fully ported ball valves provide low pressure drop, allowing a complete purge of the oil line.

- **SIMPLIFIED MAINTENANCE**

All components are easily accessible. In the event maintenance is required, the valve assembly does not have to be removed from the line.

- **COMPACT DESIGN**

The single Quad Valve™ takes up less space than multiple valve arrangements, and some multipurpose valve assemblies.

- **EASY INSTALLATION**

The Quad Valve™ comes fully assembled with preset limit switches. Pre-operational checkout or adjustments are unnecessary. All electrical connections are made in the pre-wired junction box.

- **DESIGNED FOR LONG LIFE**

The heavy-duty design ensures a long, trouble-free, operating life span.

- **POSITIVE – ACTING LIMIT SWITCHES**

Valve position limit switches are activated by the valve shaft providing a positive indication of the actual valve position. Internal interlocks prevent out-of-sequence valve operation.

Quad Valve™ Assembly

Pub # 404006-11
Rev 01/2011

Specifications

Valve Sizes:	½, ¾ and 1 inch
Valve Type:	Ball valve, with carbon-steel body, stainless steel trim
Seat Material:	TFE, RTFE, Polyfill, High-per Fill, or “G” Metal
Junction Box:	NEMA-4 (pre-wired)
Dimensions:	20.5 (H) x 18 (W) x 18 (D) inches maximum
Weight:	98 to 120 lb (depending on size)
Actuators:	Pneumatic spring return (air-to-open, spring-to-close) standard
Air Pressure:	60 – 120 psig @ 0°F – 212°F
Solenoid Valves:	4-way, 5-port solenoid valves; -10 to 135°F; 150 psig
Oil/Atomizing Valves:	Single coil standard
Purge Valve:	Single coil only
Voltages:	120 VAC, 50/60 Hz; 240 VAC, 50/60 Hz; 24 VDC; 48 VDC; 120 VDC; 240 VDC
Limit Switches	10 A @ 120 VAC, 0.4 A @ 120 VDC; NEMA-4 and 13
Closed:	DPDT (1 NO contact used internally to valve assembly)
Open:	SPDT or DPDT
Connections:	Socket weld; plain pipe; 150 lb, raised-face flange
Flow Direction:	Left to right standard (right to left optional)

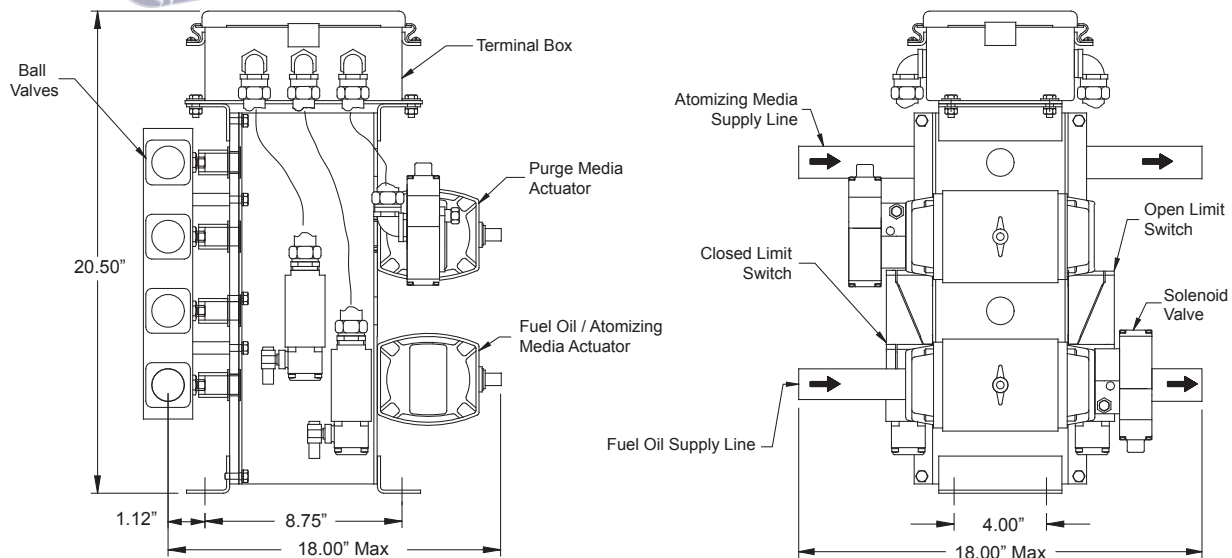

Forney Corporation

16479 North Dallas Parkway, Suite 600 • Addison, TX 75001
800-356-7740 • Fax 972-458-6650 • www.forneycorp.com